



# GRAPE GONDOLA

Collier & Miller's third generation six tonne high-capacity Grape Gondola Bin is designed to maximise your grape harvest productivity.

A favourite among local grape growers, the strong and stable C&M Grape Gondola utilises high-lift hydraulic rams to allow easy tipping of grapes to suit any height truck, while its round bottom tank design ensures ease of unloading.

## FEATURES & BENEFITS

- Fully welded stainless steel round bottom tank
- Six tonne payload
- High-lift hydraulic rams
- Self-levelling drawbar
- High-capacity axles
- Strong RHS frame
- Stable design when unloading
- Operation from tractor hydraulics



**COLLIER & MILLER**



**SCAN FOR  
MORE INFO**

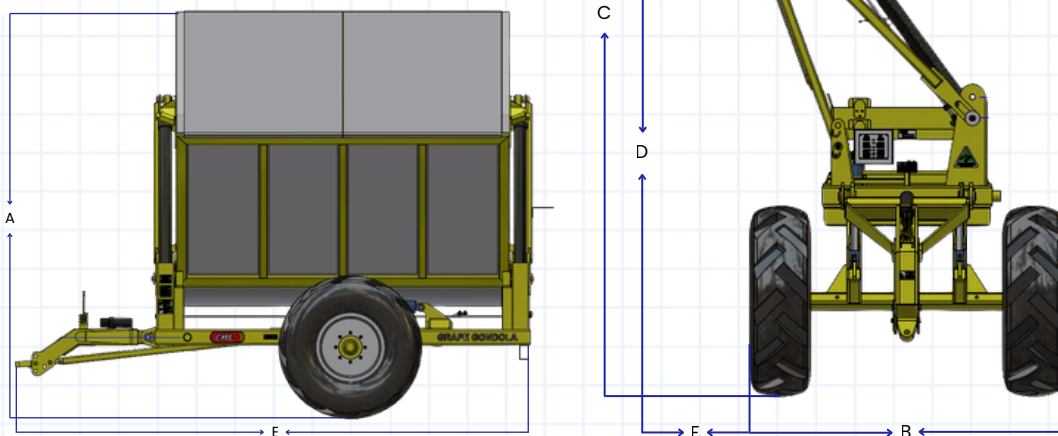

MODEL	CMGB
DESCRIPTION	C&M Stainless Steel Grape Gondola Bin
CARRYING CAPACITY	6 Tonne
A = OVERALL HEIGHT IN OPERATION	3860mm
B = OVERALL WIDTH OF WHEELS	2265mm
C = OVERALL TIPPING HEIGHT	5480mm
D = MAXIMUM TIPPING HEIGHT	3040mm low setting, 3190 high setting
E = OVERALL LENGTH	4870mm
F = TRUCK CLEARANCE	700mm
MAXIMUM DRAW BAR PIN DIAMETER	38mm
TYRE SIZE	14.00 x 24 12 ply
TRACTOR REMOTES REQUIRED TO OPERATE	2 Sets
MAXIMUM TRAVELLING SPEED WHEN LOADED	10km/ hour
TARE WEIGHT	2400kg
HYDRAULIC POWER PACK	Available upon request